



Design and Fabrication of Greenhouse Monitoring and Control System Based on Global System for Mobile Communication and Bluetooth

Nyaga S. G. , Munji M. K. , Nyenge R. L.

Department of Physics, Kenyatta University, P.O Box 43844-00100, Nairobi, Kenya

Corresponding author. E-mail: nyagastephen210@gmail.com

Received 20th June, 2022/ Accepted 18th May2023, Published online 17th November 2023

How to cite:

Nyaga, S., Munji, M., & Nyenge, R. (2023). Design and Fabrication of Greenhouse Monitoring and Control System Based on Global System for Mobile Communication and Bluetooth. *African Journal of Pure and Applied Sciences*, 4(2), 27-38. <https://doi.org/10.33886/ajpas.v4i2.411>

ABSTRACT

Greenhouse technology should be embraced as a way of minimizing food insecurity in Kenya. Greenhouses have attempted to solve this problem by enclosing crops in a climatically controlled environment. In the past, greenhouses utilized electromechanical devices such as thermostats to monitor and control the greenhouse environment. Mechanical systems lack the flexibility and precision required for greenhouse control. Some modern greenhouses use computers -based controllers, which are station- based, bulky and costly. In this study a wireless prototype greenhouse monitoring and control system that is flexible, cheap, easy to maintain and easy to assemble was developed and implemented. The hardware consisted of ATmega328 microcontroller, Global System for Mobile communication (GSM) SIM800L module, HC05 Bluetooth module, HD44780U Liquid Crystal Display (LCD) module, 5 volts 4 channel relay module, Light dependent resistor (LDR) sensor and digital humidity and temperature (DHT11) sensor. The DHT11 and LDR sensors, the relay, the LCD, the GSM and the Bluetooth modules were interfaced to the ATmega328 microcontroller, through Arduino software, a program was written in C language, developed and uploaded to the ATmega328 microcontroller to run the greenhouse prototype. The designed prototype system is able to measure temperature, humidity, and light illuminance levels in the prototype greenhouse and display the values on the LCD. The system also transmits the measured values to owner's phone via Bluetooth or GSM and keeps these

parameters at optimum levels by use of two fans, a heater, a bulb and a sprinkler. From results, when the actuators were on, the average internal temperature was 24.5 °C while the average external temperature was 31.43 °C. The average temperature control effect and cooling efficiency per hour for the designed prototype were 6.9 °C and 75.9%, respectively. At stable cooling state, the maximum cooling efficiency was 78%. This project therefore provides a cost effective and efficient means of monitoring and controlling greenhouse parameters. In addition, the system allows mobility during monitoring and control process. The agricultural sector in Kenya, can apply the designed prototype in the design and implementation of greenhouses.

Keywords: GSM module, Atmega 328, DHT11 sensor, LDR sensor, HC05 Bluetooth module.

INTRODUCTION

In Kenya, over 10 million people are food insecure, with the majority of them relying on food relief (Taneja *et al.*, 2019). This is because Kenya is a rain fed country and over 80% of her landmass falls under arid and semi-arid climate, which is characterized by droughts almost throughout the year (Huho and Kosonei, 2014; James and Maheshwar P, 2017; Mutheu, 2018). On occasions where there is rain, floods occur. These climate uncertainties have led to severe food shortage and starvation. One possible solution to achieving food security is to use greenhouses, which enable the farmer to control the growth conditions

thereby ensuring maximum crop yield throughout the year (Unicef, 2013; Vox *et al.*, 2010). Greenhouses can be automated by utilizing microcontroller-based systems that can monitor and control greenhouse parameters such as pH of soil, soil moisture, light, relative humidity and temperature, keeping them at optimum levels on a continuous 24-hour basis. In automated greenhouses, it is possible to manipulate crop production for certain economic advantages (Fuller and Zahnd, 2012; James and Maheshwar P, 2017; Kabubo-mariara and Kabara, 2015; Koross and Kipkenda, 2016).

Technology has redefined communication in many advantageous ways. Mobile technology has led to the coining of the term “global village” which can be seen through the fact that almost every adult nowadays owns a mobile phone and the decreasing cost of such devices over the years. Nowadays, cell phones are being used for more than making calls and sending messages; with the technological advancement, cell phone use has changed and various functions such as camera, radio or remote controller to control electrical appliances are standard. Short Message service (SMS) is a very popular means of communication (Plaksina and Rausch, 2011; Veena and Thakare, 2010). This concept of instant messaging is what we used in this research work to prototype a system that acts as a platform for receiving or sending messages. The messages are commands sent to a microcontroller to control various greenhouse parameters or messages sent by microcontroller showing status of greenhouse parameters. This minimizes the needed work force and maximizes the output per greenhouse. With the use of this prototype, it is not necessary for the user to be always at the greenhouse to do management practices. In this study, a prototype system based on ATmega328 microcontroller that automatically monitors and controls temperature, relative humidity and light luminance in a greenhouse using sensors, SMS technology and Bluetooth signals was designed and implemented. The designed prototype system maintained the average internal temperature of 24.5 °C and the average external temperature of 31.43 °C. The average cooling effect and cooling efficiency per hour were 6.9 °C and 75.9%, respectively. At stable cooling state, the maximum cooling efficiency of the prototype was 78%

Nyanya, (2010) designed and fabricated a greenhouse electronic system Based on the Z80 microprocessor. The hardware consisted of a Z80 CPU, two 8255 PIA s, a 2716 EEPROM, a 6116 RAM, an HIH-4000 humidity sensor, an LM-35 temperature sensor and two ADC 0804 analogue to digital converters, a clock and reset circuitry and 7-segment displays and LEDs. Vu, (2011) designed and tested a C805F020 microcontroller based automatic

greenhouse prototype. The sensing unit comprised of sensors such as SHT75 for measuring humidity and temperature, NORP12, TGS4161 for measuring carbon dioxide, THERM200 for measuring soil temperature and VG400 for measuring soil moisture. The central unit comprised of a personal computer, USB cable and 19200 bauds 2.4 GHz XStream RF modem. The central unit collected data, processed data, controlled greenhouse parameters and displayed information to the user. The coordinator unit comprised of C805F020 microcontroller, Xbee module, 19200 bauds 2.4 GHz XStream RF modem, relay interface point and power supply provided by LM2594M power regulator. The actuator unit comprised of bulbs, carbon dioxide injector, exhaust fan, sprinkler, heater and a thermal shade. Hussain *et al.*, (2013) designed and implemented a wireless greenhouse management system. The system architecture comprised of a control station and three sensor stations. The sensor stations (nodes) comprised of Xbee modules and three sensors. Jena *et al.*, (2015) fabricated a greenhouse monitoring system using on the Arduino uno board and computer. The hardware comprised of data acquisition card, Arduino board, personal computer and sensors. Hussain *et al.*, (2013) designed an intelligent greenhouse system based on LPC2148 controller. It had two nodes each node had LPC2148 microcontroller, MCP2515 controller and MCP2551 transceiver. Harishma.H, (2014) designed an embedded system for greenhouse management. The hardware comprised of the controller PIC18F452, sensors, Graphical LCD, EEPROM, Real time clock (RTC), and relays. The sensors were LM35D for temperature measurement, NORP-12-RS for measurement of light, FC-28-D for measurement of soil moisture, and SY-HS-220 for measurement of humidity. Koshy *et al.*, (2016) developed and implemented a prototype to monitor and control greenhouse climate using wireless sensors network (WSN) and internet of things. It consisted of the sensing unit, controlling part, monitoring part and message sending and receiving part. In the sensing part, the sensors included were LM35 temperature sensor, MQ-5 toxic gas sensor and fire sensor. From the research works discussed in this section, it is clear that most existing greenhouse systems lack mobility during the monitoring process. Our designed GSM and Bluetooth based remote wireless automatic monitoring system provides mobility during the monitoring process. The control and monitoring are instant and the system is programmable by the user.

Experimental

Hardware Design

Fig.1 shows a flow diagram of the designed greenhouse prototype. The designed prototype has the following units: sensing, processing and storing, displaying and

indicating, wireless communication, power supply, and actuation. The system comprises of microcontroller chip, LCD, GSM, Bluetooth, sensors, relays and actuators. The microcontroller was interfaced with two sensors to measure different greenhouse parameters such as heat levels, light luminance, and relative humidity. The analog data obtained from the light sensor was digitized via onboard ADC. The digital data was fed to the microcontroller which made

decisions and activated the relevant actuators according to the installed program. The LCD displayed sensor readings the actuator. The data provided by the sensors was recorded in EEPROM, which sent it to the microcontroller for analysis on request. The microcontroller communicated with the GSM module by AT Commands, which were used to send and receive short messages.

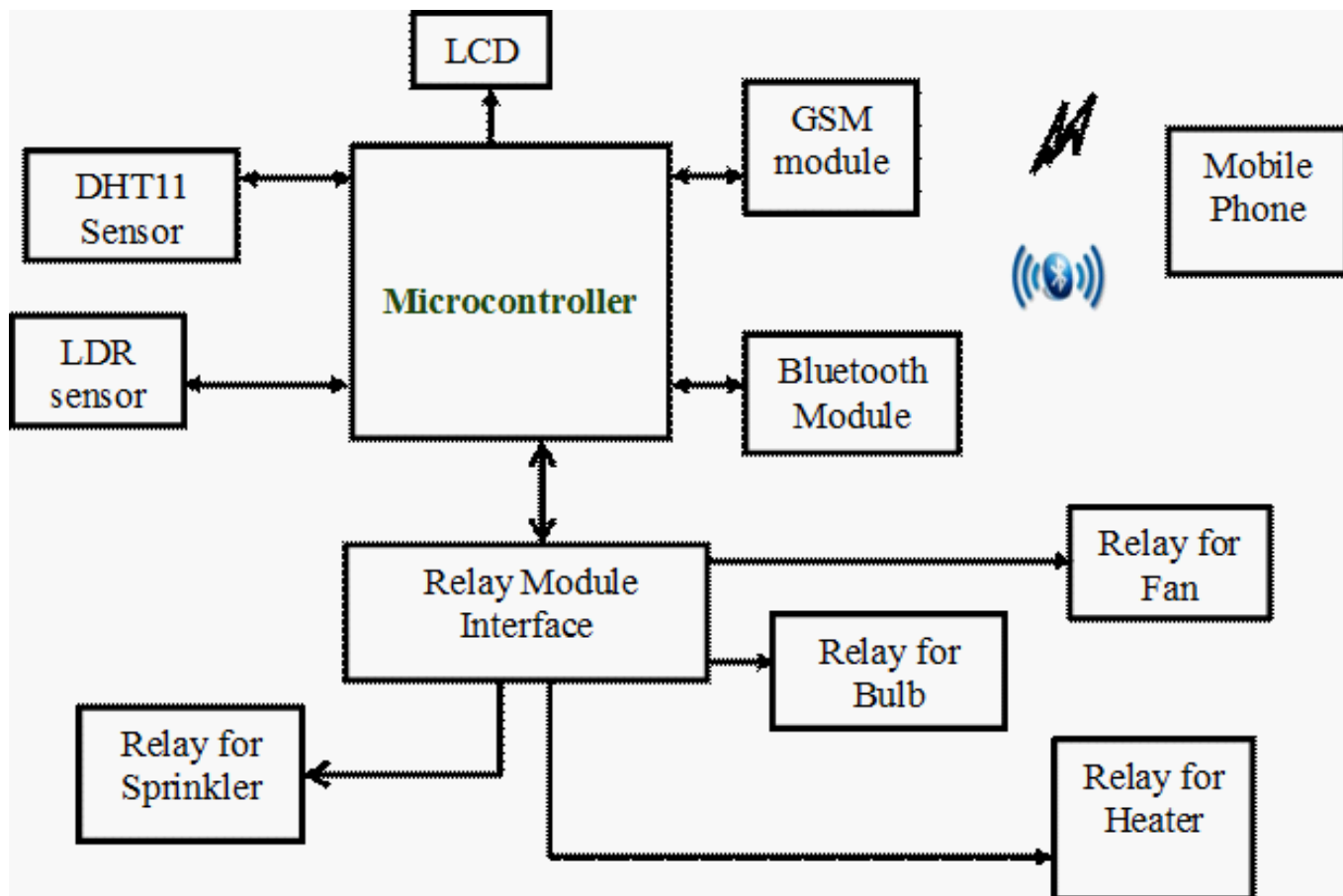

Figure 4: Prototype Block Diagram

Circuit Design of the Designed Greenhouse Electronic System

To make a microcontroller an independent computer, a 10 KΩ resistor was connected to +5 V from pin1. This prevented the microcontroller from resetting during operations. The pin 7 was connected to +5 V, pin 8 and pin 22 to the ground, pin 22 to +5 V analogue reference.

The Atmega 328 runs at 16MHZ clock speed. Therefore, a 16 MHz external oscillator was added between pin 9 and 10 with two 22 pF capacitors grounded from these pins.

Interfacing Atmega328 Microcontroller with LCD Module

The LCD module was interfaced in 4 bit mode as illustrated in fig.

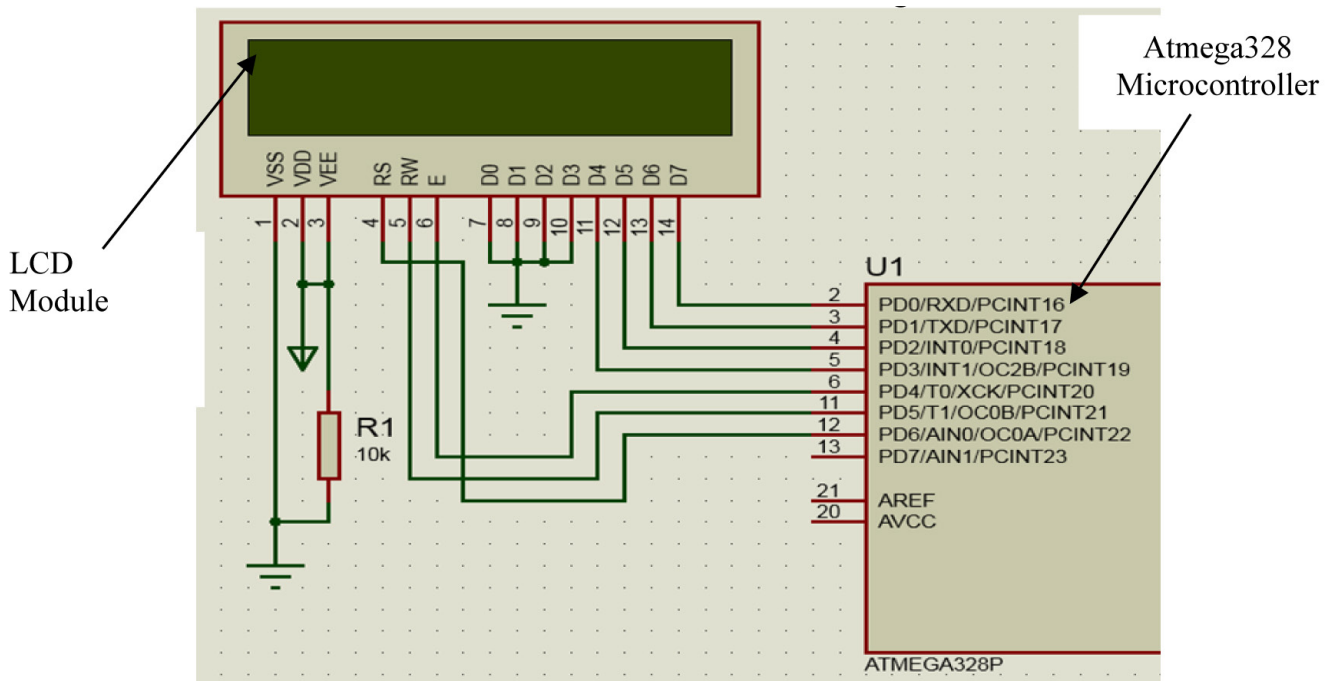

Figure 4: Liquid Crystal Display Interface to ATmega328 Microcontroller

The LCD module has 16 pins whose functions are as follows: Pin 1 (VSS): supplies low voltage power (0 V) to the LCD. Pin 2 (VDD): supplies high voltage power (5 V) to the LCD. Pin 3 (VO): used to set the LCD contrast. Pin 4 (RS): sends instructions (when set high) or data (when set low) to the LCD. Pin 5 (R/W): writes to LCD (when set low) and reads from LCD (when set high). Pin six (E): this pin sends signals to the LCD module in order to process instructions. Pin 7-14 (D0...D7): its function is to send data in binary form to or from LCD. Pin 15 (Anode): supplies high voltage power (5 V) to LCD backlight. Pin 16 (Cathode): supplies low voltage power (0 V) to LCD backlight (Atmel Corporation, 2016) (Sunrom, 2020) (GeekBot Electronics, 2012). There was no need of controlling the LCD backlight levels hence pin 16 is grounded through 100 Ω resistor. To adjust the LCD, contrast a 10 KΩ resistor was connected to pin 3 of the LCD and then grounded.

GSM SIM800L Interface to ATmega328 Microcontroller

The GSM SIM 800L was directly interfaced with Atmega 328 Microcontroller through the three lines; transmitter, receiver, and ground. Figure 3 shows the GSM SIM800L interface with Atmega328 microcontroller respectively (Hussain *et al.*, 2013) (Artawan *et al.*, 2018; Kousalya *et al.*, 2018; Mirayanti *et al.*, 2018; Shrestha, 2019; Sunny P *et al.*, 2014; Sunrom, 2020). Pin 2 of the microcontroller was connected to pin 4 of the GSM while pin 3 of the microcontroller was connected to pin 3 of the GSM. Finally pin 1 of the GSM was connected to 5 V source and pin 5 was grounded.

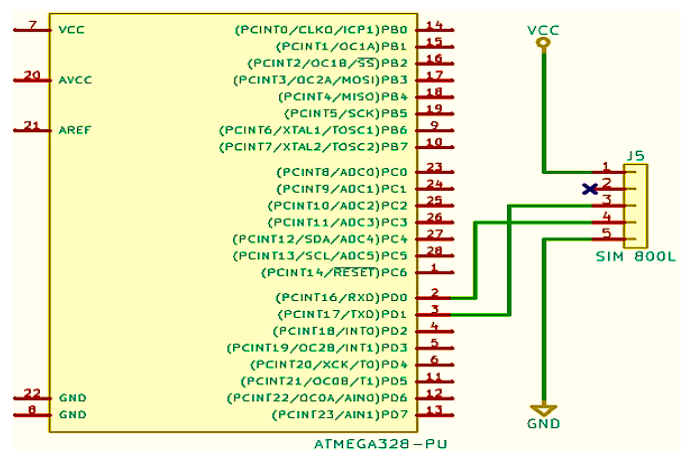

Figure 4: GSM SIM800L Interface to ATmega328 Microcontroller

HC06 Bluetooth Module Interface to ATmega328 Microcontroller

Fig. 4 show circuit connections of Bluetooth module to the ATmega328 microcontroller (GeekBot Electronics, 2012; Sunrom, 2020). Pin 5 of the microcontroller was connected to pin 2 of the Bluetooth while pin 6 of the microcontroller was connected to pin 3 of the Bluetooth. Finally pin 1 was connected to 5 V source and pin 4 was connect to ground

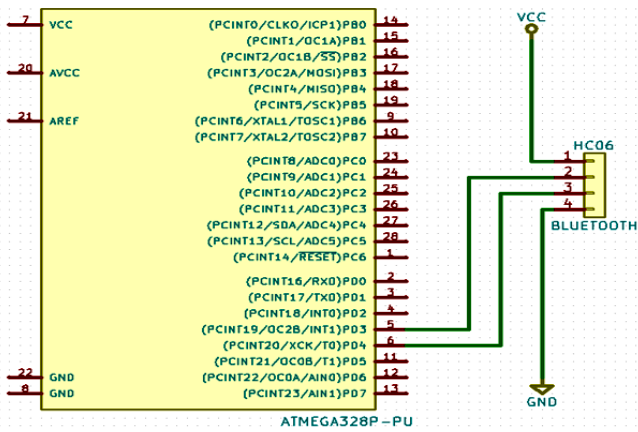

Figure 4: Bluetooth Interface to ATmega328 Microcontroller

2.6 DHT 11 Sensor Interface to ATmega328 Microcontroller

Fig. 5 shows the DHT 11 interface to the Atmega328 microcontroller. The DHT11's power supply was provided by a 5-V adapter. For power filter one capacitor valued 104 nF was interfaced at Vcc and grounded (Olalekan, 2017; Sunrom, 2020; Veena and Thakare, 2010).

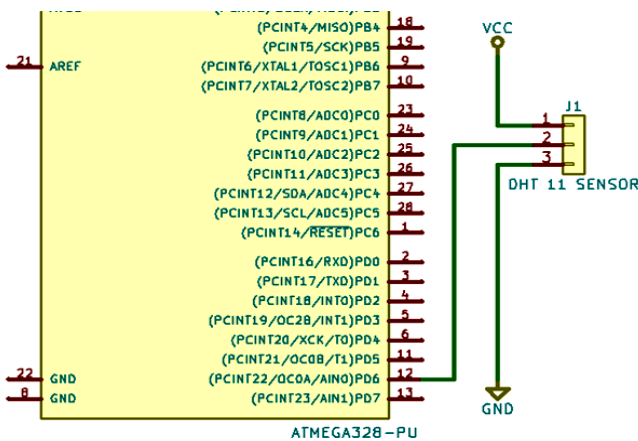

Figure 4: DHT 11 Sensor Interface to ATmega328 Microcontroller

LDR Sensor Interface to ATmega328 Microcontroller

The LDR sensor has three pins (GND, V_{CC} and OUT) and works under 5V. The LDR sensor was interfaced to ATmega328 microcontroller as shown in Fig. 6 (Durfee, 2011; GeekBot Electronics, 2012; Revolution, 2000; Sunrom, 2020; Yingxiang, 2013). First pin of the sensor was connected to ground and the second to the analog pin 0 of the microcontroller. A 10 KΩ resistor was also interfaced to the second pin and connected to power source (V_{CC}). Since the LDR gives out an analogue value it was interfaced to the analog input pin on the microcontroller. The microcontroller with its ADC then converted the analog voltage into digital value.

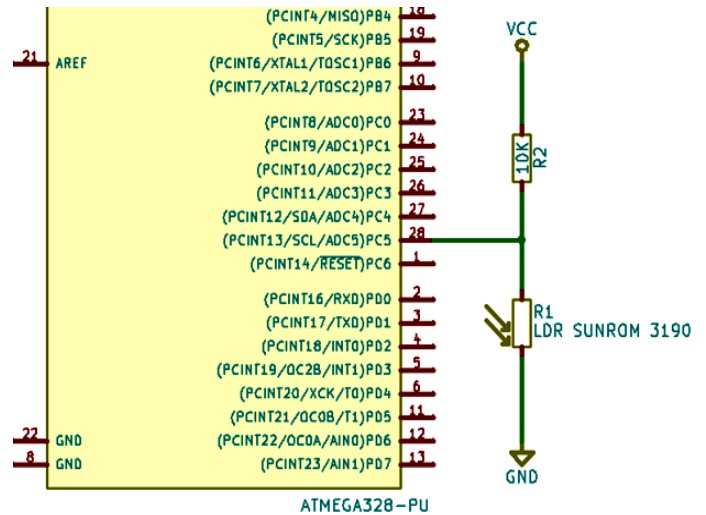

Figure 4: LDR Sensor Interface to ATmega328 Microcontroller

2.8 Relay Modules Interface to ATmega328 Microcontroller

Figure 7 shows how the 5-V 4 channel relays board was interfaced to ATmega328 microcontroller (Revolution, 2000; Yingxiang, 2013). Pin 2, pin 3, pin 4 and pin 5 and of the relays interface were connect to pin 23, pin 24, pin 25 and pin 26 of the microcontroller respectively. Pin 1 and pin 6 of the relays interface board were interfaced to power source and ground, respectively.

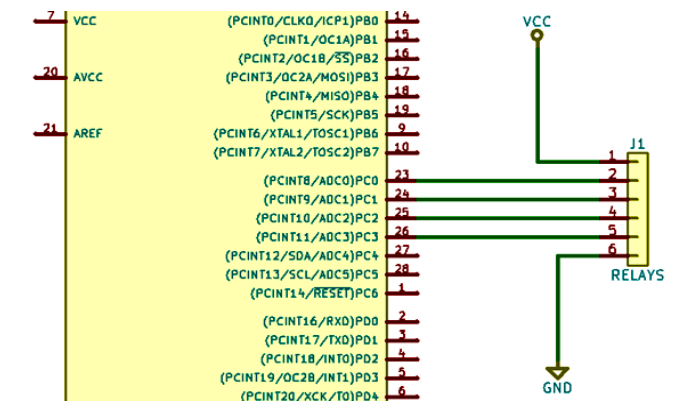

Figure 4: Relays Interface to ATmega328 Microcontroller

Complete Circuit Design of the Designed Greenhouse Electronic System

Fig. 8 shows the complete circuit design of the designed greenhouse electronic system. The sensors, the LCD module, the relay module, the GSM SIM800L module and the HC05 Bluetooth module interface to the Atmega328 microcontroller are clearly illustrated.

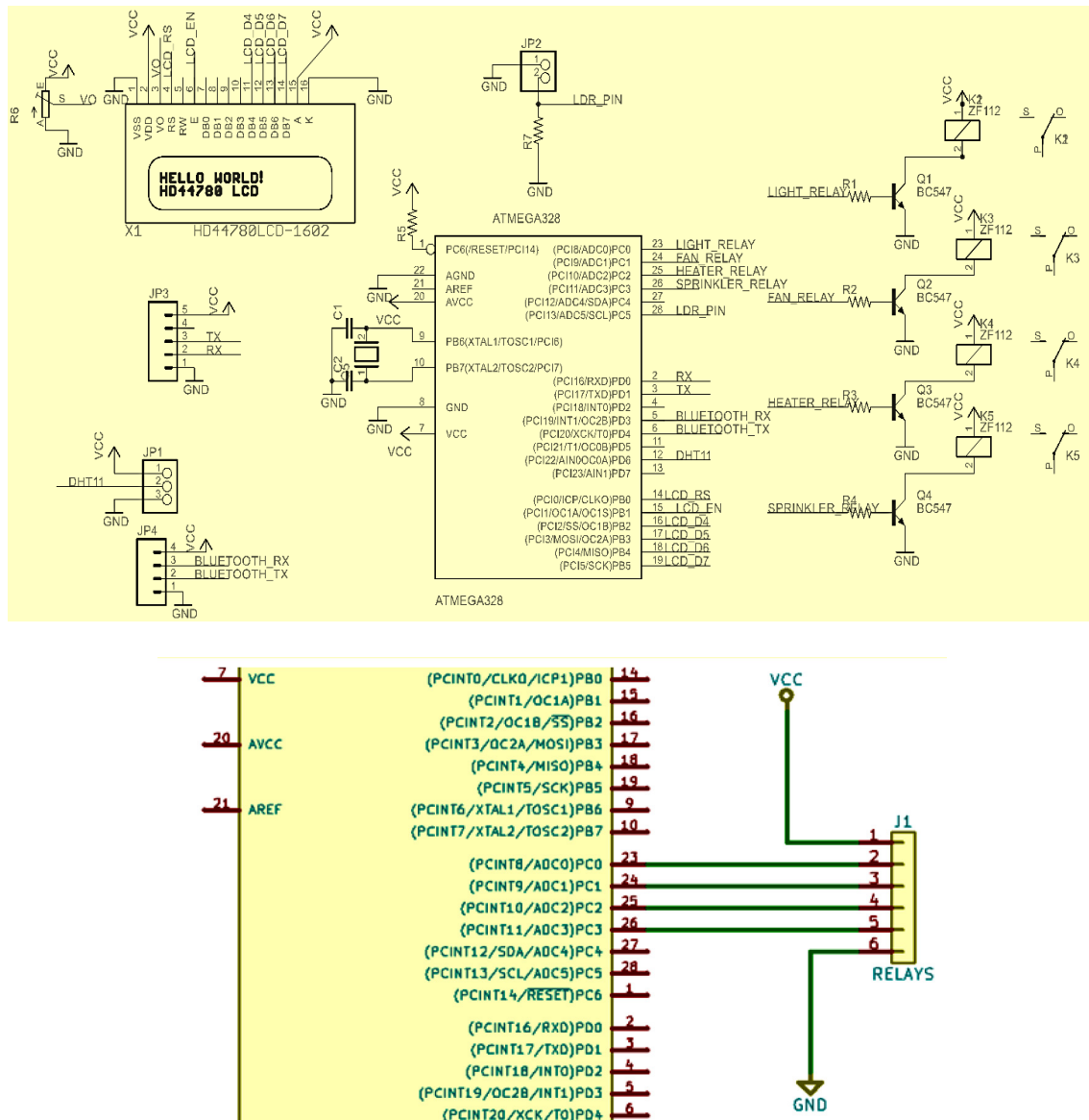

Figure 8: Circuit Diagram of the Designed Greenhouse Electronic System

Software Design

A program written in C language was developed in Arduino integrated development environment, converted to a machine code and uploaded to the Atmega328 microcontroller to run the prototype. In order to develop the program, the following steps were applied:

- i. Reset the ATmega328 ready to execute the instructions.
- ii. Initialize the sensors, GSM, Bluetooth, LCD and the relays. Send SMS “Welcome. System switched on”.
- iii. Read the DHT11 and LDR sensors.
- iv. If the temperature is within the optimum range, the software maintains status quo. If the temperature is greater than the maximum set temperature, the software checks status of the heater. If the heater is off, it turns on the fans. If heater is on, it turns off the heater then turn on the fan.
- v. If the temperature is less than the minimum set temperature, the software checks the status of the fan.

If the fan is off it turns on the heater. If the fan is on, it turns off the fan then turn on the heater. If the humidity is within the optimum range, the software maintains.

- vi. If the humidity is greater than the maximum set humidity, the software checks status of the pump. If the pump is off it turns on the fans. If pump is on, it turns off the pump then turn on the fan.
- vii. If the humidity is less than the minimum set humidity, the software checks status of the fan. If the fan is off it turns on the pump. If fan is on, it turns off the fan then turns on the pump.
- viii. If light is minimum, it turns on the lamp otherwise, it turns off the lamp.
- ix. If an error occurs during the execution process, go to step ii. Otherwise, it sends a message to the user on the greenhouse parameters and go to step iii.
- x. End.

The flow chart in fig.9 describes the above algorithms.

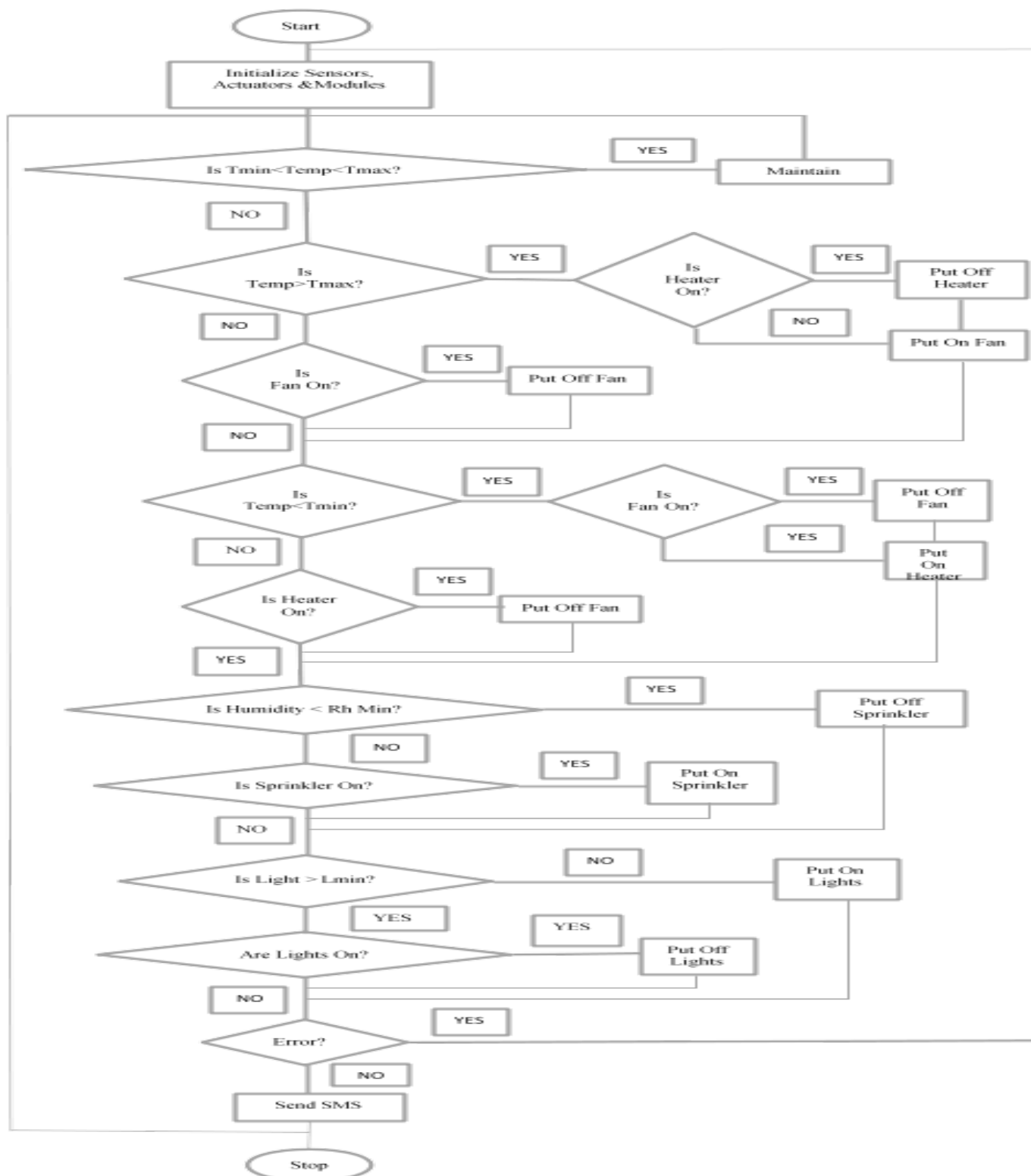

Figure 9: Software Flow Chart Diagram of the Greenhouse Electronic System

RESULTS AND DISCUSSION

To test the performance of the designed greenhouse prototype, two sets of experimental investigations were carried out. First, the sensor data was obtained from the prototype at an interval of 15 minutes for ten hours (from 8 a.m. to 6 p.m.), with actuator enabled to maintain greenhouse parameters within the optimum range. Secondly, the sensor data was obtained from the prototype

for the same period, with actuator off to show effects of the designed control system.

Table 1 shows the data for temperature with and without control from 8 a.m. to 6 p.m. The first temperature column shows values of the temperature changes with relevant control procedures while the second column shows temperature change without using control procedures.

Table 1: Temperature with and without control

Time of the Day	Temperature(°C)		Time of the Day	Temperature(°C)		Time of the Day	Temperature(°C)	
	With Control	Without Control		With Control	Without Control		With Control	Without Control
08.00 a.m.	21	16	11.30 a.m.	24	28	03.00 p.m.	20	27
08.15 a.m.	19	17	11.45 a.m.	23	29	03.15 p.m.	21	25
08.30 a.m.	21	17	12.00 a.m.	25	30	03.30 p.m.	22	26
08.45 a.m.	23	19	12.15 p.m.	24	31	03.45 p.m.	22	23
09.00 a.m.	20	18	12.30 p.m.	23	31	04.00 p.m.	24	24
09.15 a.m.	25	17	12.45 p.m.	23	29	04.15 p.m.	23	21
09.30 a.m.	24	19	01.00 p.m.	21	28	04.30 p.m.	20	22
09.45 a.m.	20	20	01.15 p.m.	20	28	04.45 p.m.	24	23
10.00 a.m.	22	22	01.30 p.m.	23	29	05.00 p.m.	22	20
10.15 a.m.	21	21	01.45 p.m.	24	29	05.15 p.m.	20	21
10.30 a.m.	23	20	02.00 p.m.	21	28	05.30 p.m.	21	18
10.45 a.m.	21	24	02.15 p.m.	23	27	05.45 p.m.	20	17
11.00 a.m.	22	25	02.30 p.m.	21	25	06.00 p.m.	23	16
11.15 a.m.	23	27	02.45 p.m.	20	26			

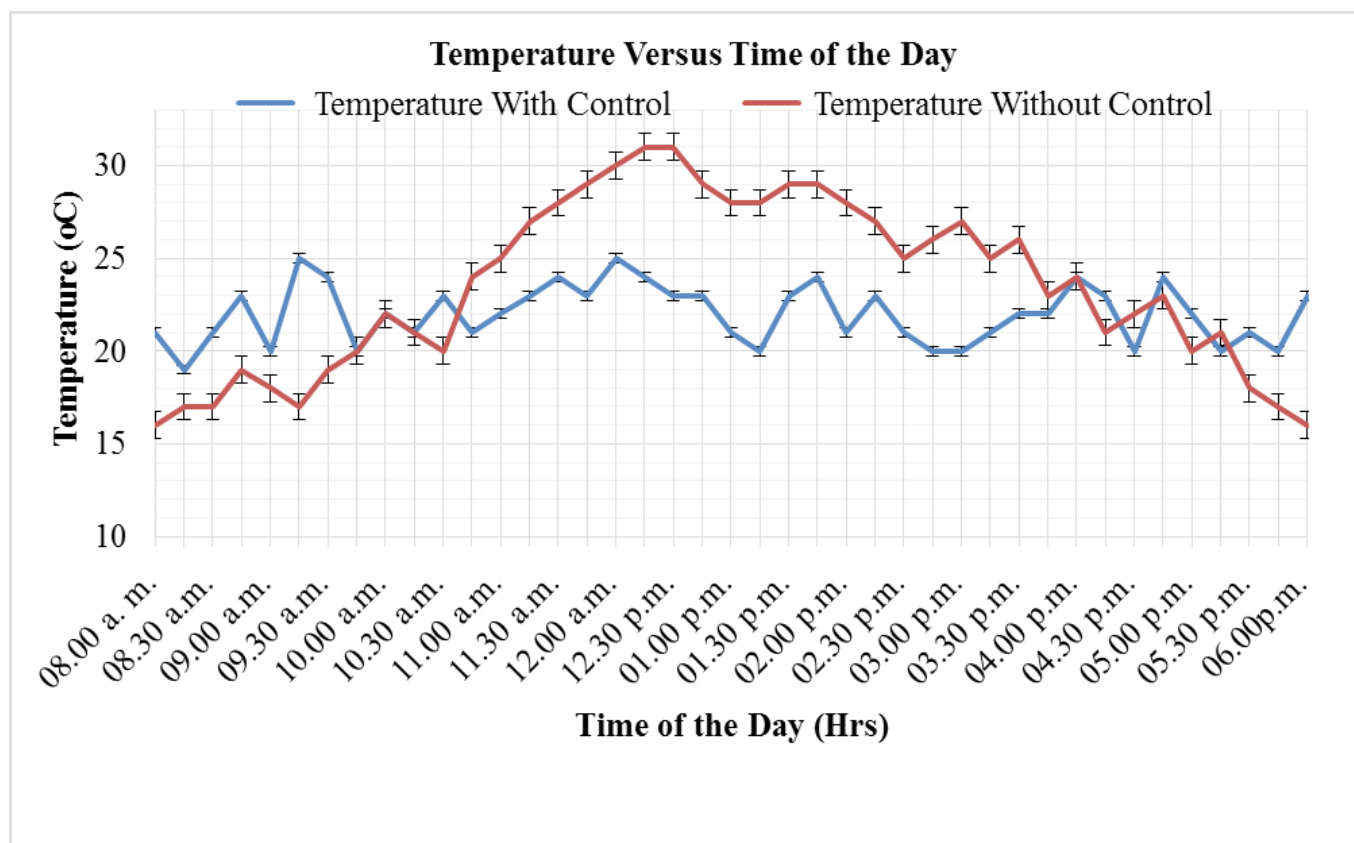

Figure 10: Greenhouse Temperature With and Without Control

Fig. 10 shows a graph of the temperature variation for the 10 hours, the red line represents the change in temperature with actuator off. It is evident that, temperature increased with time to a maximum of 31 °C at 12.30 p.m. Crop growth and development are affected by high temperatures since high temperature affect enzyme structure and their working. The blue line represents the change in temperature with actuators on. The effect of the actuators is evident in that the temperature was maintained within the optimum

levels. The range of the optimum temperature was set to a minimum of 18 °C and a maximum of 26 °C, otherwise relevant actuator was activated.

Table 2 shows the data for humidity with and without control from 8 a.m. to 6 p.m. The first humidity column shows values of the humidity change with relevant control procedures while the second column shows humidity change without using control procedures.

Table 2: Humidity with and without control

Time of the Day	Humidity (%)		Time of the Day	Humidity (%)		Time of the Day	Humidity (%)	
	With Control	Without Control		With Control	Without Control		With Control	Without Control
08.00 a.m.	69	91	11.30 a.m.	53	35	03.00 p.m.	53	21
08.15 a.m.	73	90	11.45 a.m.	60	33	03.15 p.m.	56	20
08.30 a.m.	75	82	12.00 a.m.	57	30	03.30 p.m.	51	23
08.45 a.m.	72	81	12.15 p.m.	56	29	03.45 p.m.	59	26
09.00 a.m.	70	79	12.30 p.m.	53	23	04.00 p.m.	57	31
09.15 a.m.	71	77	12.45 p.m.	57	24	04.15 p.m.	56	34
09.30 a.m.	70	78	01.00 p.m.	52	21	04.30 p.m.	57	39
09.45 a.m.	66	76	01.15 p.m.	51	19	04.45 p.m.	61	45
10.00 a.m.	64	66	01.30 p.m.	48	17	05.00 p.m.	59	47
10.15 a.m.	60	65	01.45 p.m.	57	18	05.15 p.m.	60	58
10.30 a.m.	65	63	02.00 p.m.	58	18	05.30 p.m.	62	63
10.45 a.m.	66	59	02.15 p.m.	59	20	05.45 p.m.	63	70
11.00 a.m.	57	37	02.30 p.m.	60	21	06.00 p.m.	65	75
11.15 a.m.	58	38	02.45 p.m.	56	20			

Fig. 11 shows the graph of humidity readings for the 10 hours. The red line represents the change in humidity with the actuators off. It is evident that humidity decreased to 17 % by 1:30 p.m. crops growing in dry air lose a lot of water through the process of transpiration. Similarly, if humidity is above 80%, there is a risk of spread of fungal diseases. In both cases crops can be affected during flowering and fruit

development stages, hence controlling humidity is crucial. The blue line represents the change of humidity with actuator enabled; it is evident that humidity levels were maintained within the optimum range throughout the test period. The range of the optimum humidity was set to a minimum of 40% and a maximum of 80%, otherwise relevant actuator was activated.

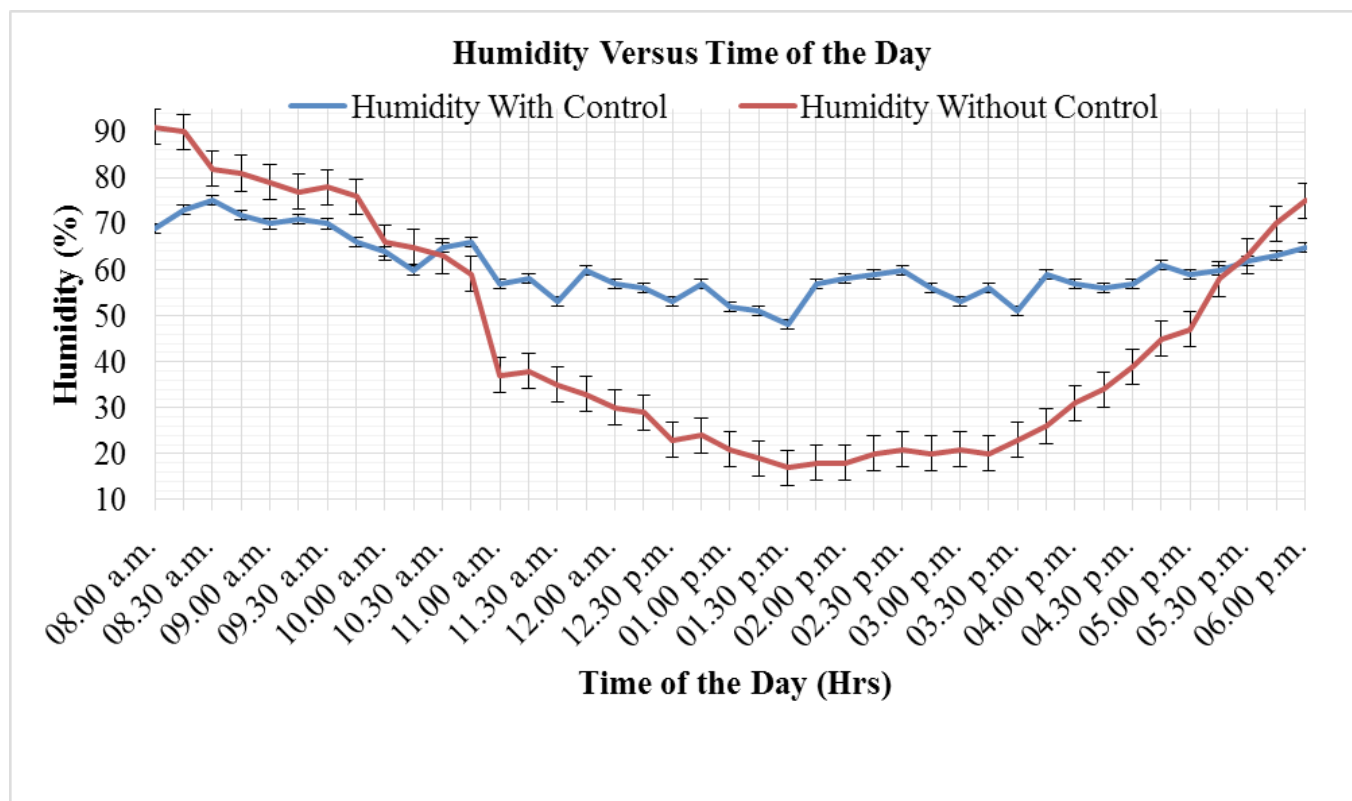

Figure 11: Greenhouse Humidity With and Without Control

Table 3 shows the data for light intensity with and without control for the 10 hours. The first light column shows values of the light intensity changes with relevant control

procedures while the second column shows light intensity change without using control procedures.

Table 3: Light Intensity With and Without Control

Time of the Day	Light Intensity (Lx)		Time of the Day	Light Intensity (Lx)		Time of the Day	Light Intensity (Lx)	
	With Control	Without Control		With Control	Without Control		With Control	Without Control
08.00 a.m.	640	286	11.30 a.m.	830	751	03.00 p.m.	678	798
08.15 a.m.	598	243	11.45 a.m.	829	811	03.15 p.m.	613	600
08.30 a.m.	618	372	12.00 a.m.	915	923	03.30 p.m.	641	425
08.45 a.m.	625	389	12.15 p.m.	931	1001	03.45 p.m.	621	329
09.00 a.m.	551	384	12.30 p.m.	923	1031	04.00 p.m.	634	331
09.15 a.m.	534	381	12.45 p.m.	949	1021	04.15 p.m.	690	302
09.30 a.m.	542	390	01.00 p.m.	967	1060	04.30 p.m.	679	273
09.45 a.m.	619	387	01.15 p.m.	989	1080	04.45 p.m.	667	245
10.00 a.m.	687	580	01.30 p.m.	967	1085	05.00 p.m.	645	134
10.15 a.m.	615	621	01.45 p.m.	983	1083	05.15 p.m.	614	105
10.30 a.m.	611	675	02.00 p.m.	980	1092	05.30 p.m.	634	128
10.45 a.m.	688	674	02.15 p.m.	970	985	05.45 p.m.	623	123
11.00 a.m.	694	690	02.30 p.m.	969	982	06.00 p.m.	613	118
11.15 a.m.	823	683	02.45 p.m.	973	880			

A graph of the variation of light intensity with time was plotted. The red line represents the light intensity with the actuator off. It is evident that light intensity increased with time to a maximum value of 1092 lux at 2:00 p.m. and drops to 118 lux at 6:00 p.m. Light affects crop growth

since high light intensity increases transpiration while crops growing in dark are weak. The blue line represents light intensity with actuators on. This implies that the system was able to maintain light above 500 lux, which is the optimum light intensity for proper growth and development of crops.

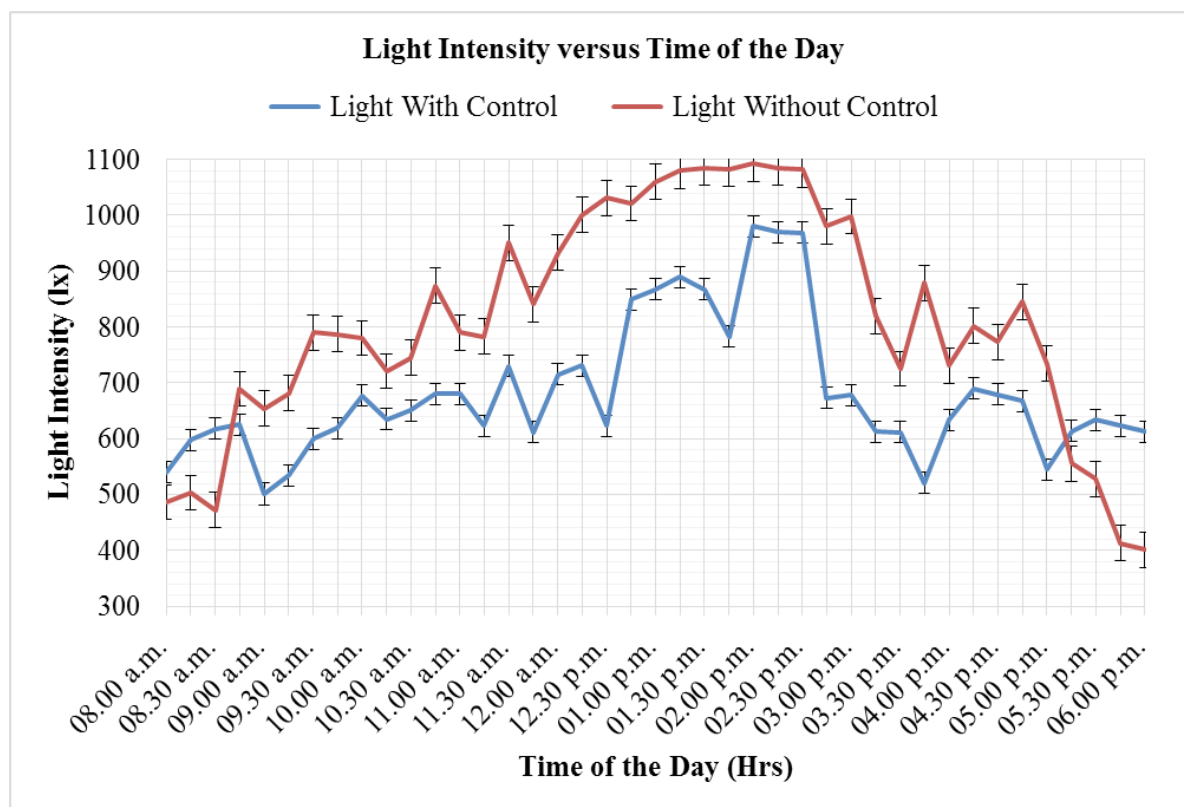

Figure 12: Greenhouse light intensity with and without control

CONCLUSION

In this work, design and implementation of a microcontroller-based system to monitor and control greenhouse parameters has been achieved. The designed system uses sensors, SMS technology and Bluetooth signals. This prototype is able to measure temperature levels, humidity levels and light luminance values in the greenhouse. In addition, it displays the values on LCD, transmits them to the linked device such as phone, tablet e.t.c via the Bluetooth or GSM modules. Finally, the designed prototype keeps these parameters at optimum levels by use of fans, heater, bulb and sprinkler.

REFERENCES

- Artawan, M. D., Ngurah Gunawan, A. A., & Sumadiyasa, M. (2018). Use of short message service (SMS) based ATmega328 microcontroller and SIM800L modules as on / off control electronic equipments. *Advances in Applied Physics*, 6(1), 19–24. <https://doi.org/10.12988/aap.2018.856>
- Atmel Corporation. (2016). *Atmel ATmega328/P Datasheet*. Atmel. www.atmel.com
- Durfee, W. (2011). Arduino Microcontroller Guide. In *University of Minnesota*. www.me.umn.edu/courses/me2011/arduino/
- Fuller, R., & Zahnd, A. (2012). Solar greenhouse technology for food security: A case study from Humla District, NW Nepal. *Mountain Research and Development*, 32(4), 411–419. <https://doi.org/10.1659/MRD-JOURNAL-D-12-00057.1>
- Harishma.H. (2014). Designing an Embedded System for the Parameter Monitoring and Control Inside a Greenhouse. *International Journal of Research in Engineering and Technology*, 03(19), 448–451. <https://doi.org/10.15623/ijret.2014.0319080>
- Huho, J., & Kosonei, R. (2014). Understanding Extreme Climatic Events for Economic Development in Kenya. *IOSR Journal Of Environmental Science, Toxicology And Food Technology*, 8, 2319–2399. <https://doi.org/10.9790/2402-08211424>
- Hussain, R. H., Marhoon, A. F., & Rashid, M. T. (2013). Wireless Monitor and Control System for Greenhouse. *International Journal of Computer Science and Mobile Computing*, 2(January), 69–87.
- James, J., & Maheshwar P, M. (2017). Plant growth monitoring system, with dynamic user-interface. *IEEE Region 10 Humanitarian Technology Conference 2016, R10-HTC 2016 - Proceedings*. <https://doi.org/10.1109/R10-HTC.2016.7906781>
- Jena, S. P., Aman, S., & Das, R. (2015). Computerized Green House Data Acquisition System Using Arduino with LabVIEW. *International Journal Od Advenced Research in Electrical, Electronics and Instrumentation Engineering*, 4(4), 2350–2357.
- Kabubo-mariara, J., & Kabara, M. (2015). *Environment for Development Climate Change and Food Security in Kenya*.
- Koross, R., & Kipkenda, P. K. (2016). The Short Message Service (SMS) Texting Style of Communication and Its impact on Kenyan University Students ' Written Communication Skills. *International Journal of Scientific Research and Innovative Technology*, 3(6), 151–162.
- Koshy, R., Yaseen, M. D., Fayis, K., Shaji, N., Harish, N. J., & Ajay, M. (2016). Greenhouse Monitoring and Control Based on IOT Using WSN. *ITSI Transactions on Electrical and Electronics Engineering (ITSI-TEEE)*, 4(3), 59–64.
- Kousalya, T., Vishnu, A., Rajeshwaran, T., & Sunil, B. (2018). Intelligent Control of Electronic Appliances Using Remote GSM. *International Research Journal of Engineering and Technology (IRJET)*, 5(1), 776–780.
- Mirayanti, N. K. R., Gunawan, A. A. N., & Sutapa, I. G. N. (2018). Humidity monitoring system for oyster mushroom cultivation room by web based AVR ATmega328P-PU. *Advances in Applied Physics*, 6(1), 9–13. <https://doi.org/10.12988/aap.2018.813>
- Mutheu, M. (2018). Information and communication technology (ICT) in greenhouse farming : Smallholder farmers training programme in Kenya. *Journal of Agricultural Extension and Rural Development Full*. <https://doi.org/10.5897/JAERD>
- Nyanya, W. O. (2010). *Design and Fabrication of an Electronic System for Monitoring and Controlling Temperature , Light Illuminance and Humidity in a Greenhouse* (Issue April). Kenyatta University.
- Olalekan, O. B. (2017). Development of a Sim800l Based Reprogrammable Household Smart Security System with Recipient Phone Call Alert. *International Journal of Computer Engineering In Research Trends*, 4(1), 15–20.
- Plaksina, O., & Rausch, T. (2011). Development of a KNX-Based Greenhouse Climate Control. *Journal of Physics A: Mathematical and Theoretical*, 44(8), 1689–1699. <https://doi.org/10.1088/1751-8113/44/8/085201>
- Revolution. (2000). Section 3. In *Microcontroller Interfacing Circuits* (pp. 1–44). Revolution Education Ltd. Business Innovation Centre, Innova Park, Mollison Avenue, Enfield, Middlesex, EN3 7XU. www.rev-ed.co.uk%0Arevolution
- Shrestha, R. (2019). Study and Control of DHT11 Using Atmega328P Microcontroller. *International Journal of Scientific & Engineering Research*, 10(4), 518–521.
- Sunny P, J., Siddesh R, G., & Kiran D, H. (2014). Industrial Parameter Monitoring and Controlling

- Using Gsm and Web Server. *IOSR Journal of Electrical and Electronics Engineering*, 9(2), 71–73. <https://doi.org/10.9790/1676-09267173>
- Sunrom. (2020). *Light Dependent Resistors Datasheet*. Sunrom Technologies. <https://doi.org/10.4324/9780080574714-24>
- Taneja, H., Gupta, M., Kaushik, P., & Delhi, N. (2019). Home Automation Using Dtmf. *International Journal of Science Technology & Engineering*, 06(1), 184–187.
- Unicef. (2013). *Food Security Research Findings and Recommendations Nairobi County*. University of Nairobi Press Jomo Kenyatta Memorial Library.
- Veena, K. K., & Thakare, V. M. (2010). Short Message Service using SMS Gateway. *International Journal on Computer Science and Engineering*, 02(04), 1487–1491.
- Vox, G., Teitel, M., Pardossi, A., Minuto, A., Tinivella, F., & Schettini, E. (2010). Sustainable Agriculture: Technology, Planning and Management. In A. Salazar & I. Rios (Eds.), *Sustainable Greenhouse Systems* (Issue March 2016, pp. 1–79). Nova Science Publishers, Inc.
- Vu, Q. M. (2011). *Automated Wireless Greenhouse Management System*. Massey University.
- Yingxiang, L. (2013). Research and Implementation on Temperature and Humidity Measurement System Based on FBG BT. In Z. Du (Ed.), *Proceedings of the 2012 International Conference of Modern Computer Science and Applications* (pp. 633–637). Springer Berlin Heidelberg.

ACKNOWLEDGEMENTS

Praise to Almighty God for guiding and protecting me throughout this work. I am grateful to all my lecturers in Physics department of Kenyatta University for their valued mentorship and advice throughout this research project. Thanks to all technical staff within the department of Physics, particularly Mr. Fred Mudimba, the chief laboratory technician, for all of their help. A deep thank to my colleague Moses Irungu for his wonderful support and academic mentoring during my research. I fully thank all the persons who have been involved in this thesis. Thanks a million, to my family for their encouragement throughout the studies.